

# HL225-6

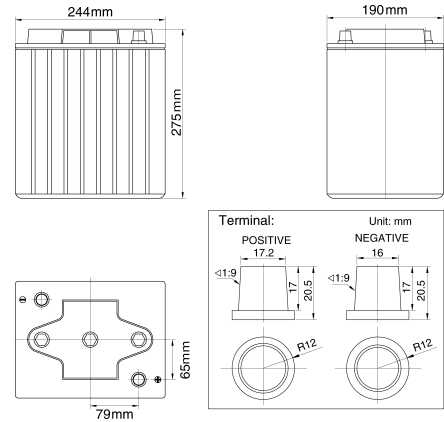

## Specifications

Nominal Voltage		6V
Rated Capacity(20 hour rate)		225AH
Dimension	Total Height (with terminals)	275mm(10.83inches)
	Height	275mm(10.83inches)
	Length	244mm(9.61inches)
	Width	190mm(7.48inches)
Weight		Approx.36.0kg(79.37lbs)

## Characteristics

Capacity 77°F(25°C)	20 hour rate(11.25A)	225AH
	10 hour rate(20.93A)	209.3AH
	5 hour rate(38A)	190AH
	1 hour rate(135A)	135AH
Internal Resistance	Full charged Battery 77°F(25°C)	1.5mΩ
	104°F(40°C)	102%
Capacity affected by Temperature (20 hour rate)	77°F(25°C)	100%
	32°F(0°C)	85%
	5°F(-15°C)	65%
Self-Discharge 77°F(25°C)	Capacity after 3 month storage	88%
	Capacity after 6 month storage	76%
	Capacity after 12 month storage	53%
Max. Discharge Current 77°F(25°C)		3375A(5S)
Terminal	Standard	Special
	Optional	
Charging (Constant Voltage)	Cycle	Initial Charging Current 45A Or Small 7.25V~7.45V/77°F(25°C)
	Float	6.8V~6.9V/77°F(25°C)

## Constant Power Discharge Watts Per Cell @ 77°F(25°C)

End Point Volt/cell	Operation Time To End Point Voltage								
	5min	10min	15min	20min	30min	40min	50min	60min	90min
1.75	923	757	643	560	444	360	310	273	180
1.70	978	800	670	584	455	373	315	274	183
1.67	1034	833	693	588	461	374	321	276	187
1.65	1045	844	705	596	466	376	324	280	191
1.60	1103	879	727	617	472	382	326	282	193

## Constant Current Discharge Rating Amperes @ 77°F(25°C)

End Point Volt/cell	Operation Time To End Point Voltage													
	5min	10min	30min	60min	2hr	3hr	4hr	5hr	6hr	7hr	8hr	10hr	20hr	24hr
1.75	499	350	234	135	78.2	56.3	44.1	36.0	31.3	27.9	25.3	20.9	11.3	9.43
1.80	463	323	221	131	76.5	54.4	42.8	35.1	30.4	27.0	24.2	20.3	11.0	9.24
1.85	365	276	195	120	70.5	51.2	40.5	33.3	28.9	25.8	23.1	19.4	10.5	8.82
1.90	274	232	168	103	64.9	47.3	37.7	31.0	26.8	24.0	21.6	18.2	9.79	8.22

## Discharge characteristics 77°F(25°C)

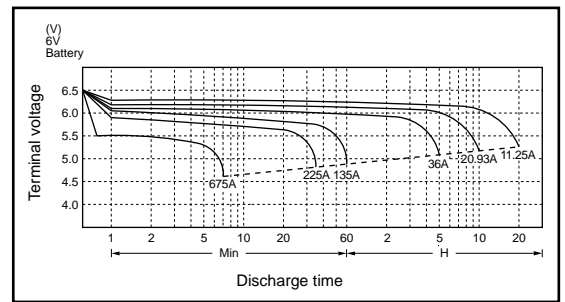

## Duration of discharge vs. Discharge current

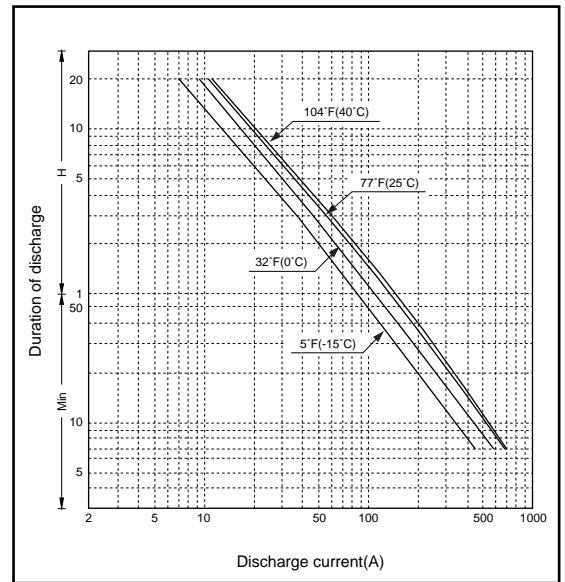

**Note** The above data are average values, and can be obtained within 3 charge/discharge cycles. These are not minimum values.