

# HL210-12

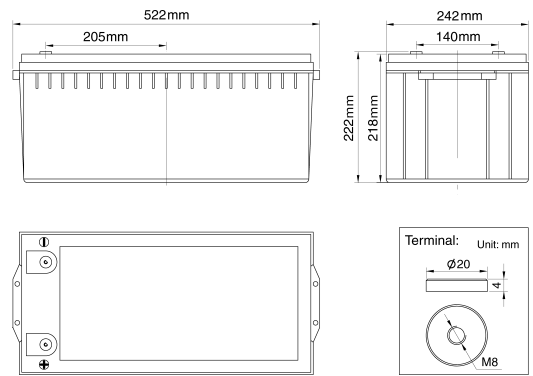

## Specifications

Nominal Voltage		12V
Rated Capacity(20 hour rate)		210AH
Dimension	Total Height (with terminals)	222mm(8.74inches)
	Height	218mm(8.58inches)
	Length	522mm(20.55inches)
	Width	242mm(9.53inches)
Weight		Approx.76.5kg(168.65lbs)

## Discharge characteristics 77°F(25°C)

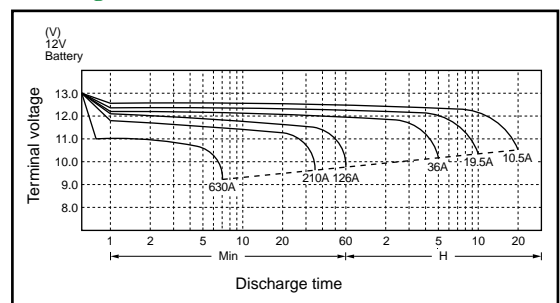

## Characteristics

Capacity 77°F(25°C)	20 hour rate(10.5A)	210AH
	10 hour rate(19.5A)	195.3AH
	5 hour rate(36A)	180AH
	1 hour rate(126A)	126AH
Internal Resistance	Full charged Battery 77°F(25°C)	2mΩ
Capacity affected by Temperature (20 hour rate)	104°F(40°C)	102%
	77°F(25°C)	100%
	32°F(0°C)	85%
	5°F(-15°C)	65%
Self-Discharge 77°F(25°C)	Capacity after 3 month storage	91%
	Capacity after 6 month storage	82%
	Capacity after 12 month storage	64%
Max. Discharge Current 77°F(25°C)	3150A(5S)	
Terminal	Standard	F17
	Optional	F10
Charging (Constant Voltage)	Cycle	Initial Charging Current 42A Or Small 14.5V~14.9V/77°F(25°C)
	Float	13.6V~13.8V/77°F(25°C)

## Duration of discharge vs. Discharge current

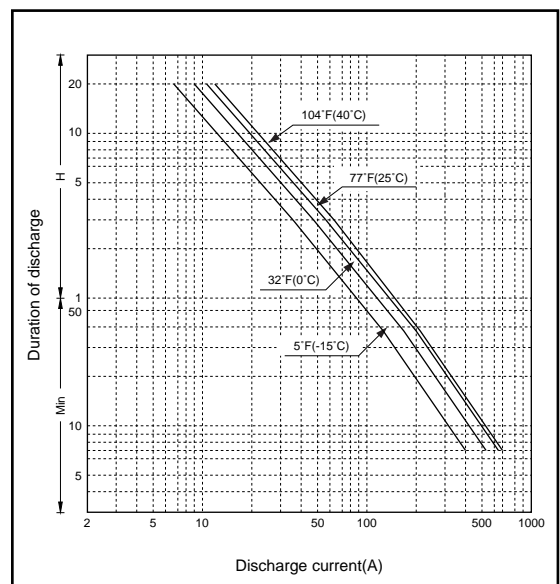

**Note** The above data are average values, and can be obtained within 3 charge/discharge cycles. These are not minimum values.

## Constant Power Discharge Watts Per Cell @ 77°F(25°C)

End Point Volt/cell	Operation Time To End Point Voltage								
	5min	10min	15min	20min	30min	40min	50min	60min	90min
1.75	873	711	602	524	415	336	289	254	173
1.70	925	752	628	545	425	348	294	255	175
1.67	978	783	649	550	430	349	299	257	178
1.65	988	794	660	558	435	351	302	261	182
1.60	1041	826	681	577	441	357	304	263	184

## Constant Current Discharge Rating Amperes @ 77°F(25°C)

End Point Volt/cell	Operation Time To End Point Voltage													
	5min	10min	30min	60min	2hr	3hr	4hr	5hr	6hr	7hr	8hr	10hr	20hr	24hr
1.75	472	327	218	126	73.0	52.5	41.2	36.0	30.8	27.0	24.2	19.5	10.5	8.80
1.80	436	302	206	123	71.4	50.7	39.9	35.1	30.0	26.2	23.3	18.9	10.3	8.62
1.85	345	259	182	113	65.8	47.8	37.8	33.4	28.4	24.9	22.2	18.1	9.76	6.23
1.90	259	217	156	96.3	60.6	44.1	35.2	31.0	26.4	23.2	20.8	16.9	9.14	7.67